



ECO-FRIENDLY HEAT PUMP *water heating systems*



COMMERCIAL
solutions

SPLIT SYSTEM

heat pump water heaters (HPWH)

With a proven 10-year track record across North America, the 5th generation SANCO2 heat pump technology represents the pinnacle of sustainable water heaters for your commercial building – natural, efficient and economical. Choose SANCO2 and step into the future of water heating.

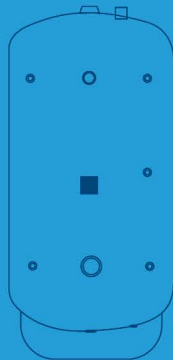

**119, 200, 285,
360, 455, 505
GALLON**
commercial tanks

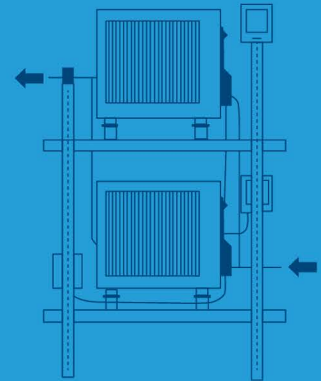

SANCO2
module



GEN₅

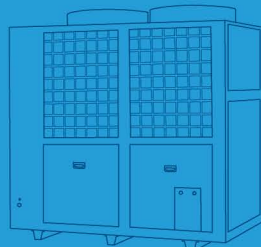

40kW
heat pump



4.5 or 6kW
heat pump



BUILD YOUR COMMERCIAL SYSTEM

SANCO₂ commercial water heating systems consist of multiple components, including heat pumps, storage tanks, swing tanks, buffer tanks, controllers, freeze protection, mounting materials and other accessories.

10 STEPS TO BUILD YOUR COMMERCIAL SANCO₂ SYSTEM:

1 DETERMINE HOT WATER DEMAND

Use the sizing tool to determine how much hot water is used daily at your site. Based on the number of gallons consumed, the tool will recommend the number of SANCO₂ heat pumps and tanks needed.

2 SELECT SIZE & NUMBER OF STORAGE TANKS

The SANCO₂ commercial tank lineup consists of six models for main storage: including 119, 200, 285-, 360-, 455-, and 505-gallon sizes.

3 DETERMINE NEED & SIZE OF SWING TANK

A swing tank is typically needed when the number of heat pump units at the job site exceeds twelve. SANCO₂ swing tanks are available in 80-, 119- and 200-gallon sizes.

4 DETERMINE NEED & SIZE OF BUFFER TANK

When the pipe length between the storage tank and the SANCO₂ heat pump exceeds 66 feet, a buffer tank may be needed. These are available in 43, 83, 119 and 200 gallons.

5 SELECT HEAT PUMP & QUANTITY

Select a heat pump with enough capacity to meet the site's hot water demand while accounting for layout, design, and installation constraints. SANCO₂ units come in 4.5 kW, 6 kW, and 40 kW capacities, and the SANCO₂ Module offers a pre-engineered kit combining 2–8 heat pumps of either 4.5 kW or 6 kW.

6 SELECT CONTROLLER

To monitor system operating parameters, control heat pump operation and assure maximum efficiency, SANCO₂ offers its proprietary Commercial System Controller.

7 SELECT ACCESSORIES

Optional accessories are available to complete the SANCO₂ System, including mounting materials, freeze protection, and heat tapes.

8 DETERMINE HEAT PUMP/TANK LAYOUT & PIPING

Visit the ECO₂ website to explore standard configurations to accelerate your installation design. eco2waterheater.com/commercial/application-drawings

9 PARTNER WITH AN ECO₂ CERTIFIED CONTRACTOR

ECO₂ has a robust network of professional contractors who specialize in sustainable commercial water heater systems. They design, install and provide ongoing product support. To find a contractor near you, visit eco2waterheater.com/where-to-buy-professionals

10 CHOOSE ECO₂ START-UP SERVICE

Partner with ECO₂ to receive a comprehensive analysis of your layout, piping, manifold, operational performance, and amp draw of the storage tanks and the heat pumps.



TO LEARN MORE, VISIT eco2waterheater.com/commercial

SUPERIOR COMPONENT DESIGN

FIFTH-GENERATION HEAT PUMPS

- **Natural Refrigerant (CO₂)** – highly efficient method for heating water.
- **Operates in cold temperatures** – producing hot water below -25°F ambient temperature without supplemental electric resistance heating elements.
- **Inverter Compressor** – increases efficiency by varying the speed of the compressor and hence the amount of electrical energy used.
- **DC Fan & Water Pump** – powered by direct current (DC) allowing both to run at a speed based on load requirements to optimize energy efficiency
- **Gas Cooler** – optimized design enables industry leading heat transfer efficiency from CO₂ refrigerant to water.

CUSTOMIZED STORAGE TANKS

- **The SANCO₂ line up of 285 to 505-gallon glass lined tanks** feature Ultonium and Microban coatings to eliminate corrosion and prevent bacteria growth.
- **Stratification** – proprietary design creates separation of water into horizontal layers with warmer water floating above colder water resulting in higher performance.
- **Water Connections** – optimized water inlet and outlet locations.
- **Space Optimization** – tank location does not require any ventilation.

OPTIMAL SYSTEM INTEGRATION

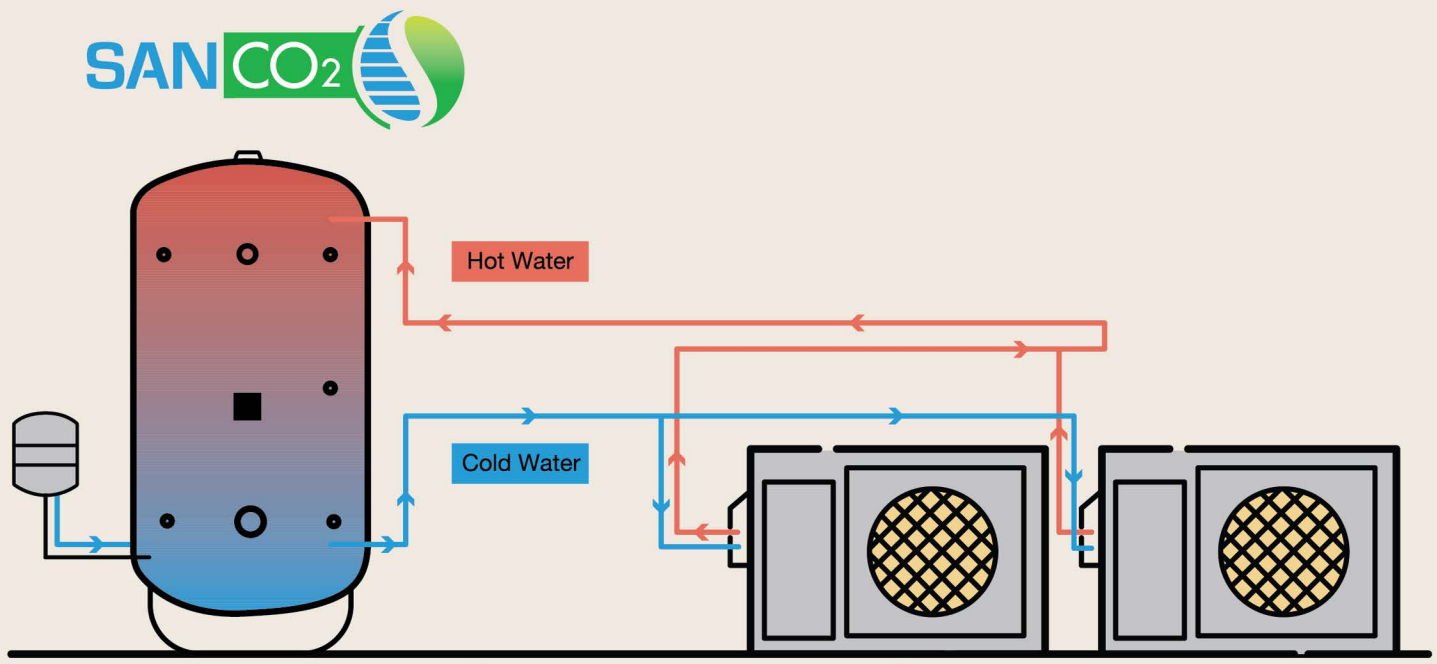

EXPERIENCE THE DIFFERENCE WITH SANCO₂



FAST RECOVERY from a hot water draw at 20+ GPH of 150°F water to the top of the tank.



HEAT PUMP WILL MAKE HOT WATER below -25°F to 114°F ambient temperature.



HIGH COEFFICIENT OF PERFORMANCE (COP) ratings deliver greater efficiency.



LONGEST AND MOST COMPREHENSIVE WARRANTY on the market.



MOST ENVIRONMENTALLY FRIENDLY water heater on the market: CO₂ refrigerant has a low global warming potential.



COMMERCIAL CONTROLLER allows system staging, BacNet, Cloud access, and load shift.

BUILD YOUR IDEAL COMMERCIAL SYSTEM FROM A BROAD SELECTION OF OFFERINGS:

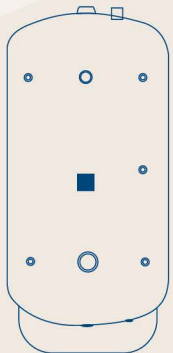

119, 200, 285, 360, 455, 505 GALLON
commercial tanks

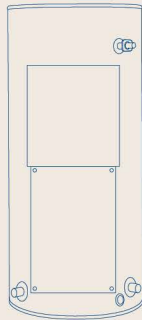

80, 119, 200 GALLON
swing tanks

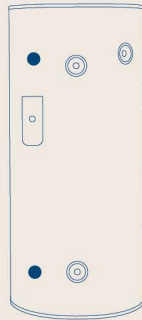

43, 83, 119, 200 GALLON
buffer tanks



controller



4.5 or 6kW
heat pump

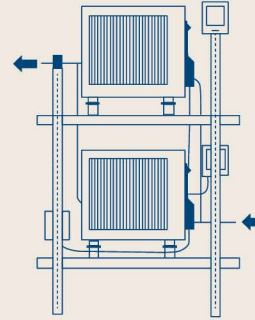

SANCO₂
module

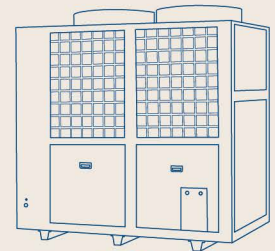

40kW
heat pump

HEAT PUMP	4.5kW	6kW (preliminary)	SANCO ₂ Module	40kW (preliminary)
PERFORMANCE				
RECOVERY RATE @90°F Rise (GPH)	20.6	27.3	41.2-164.8	201.0
AMBIENT TEMP RANGE	-25 to 114°F	-25 to 114°F	-25 to 114°F	-25 to 114°F
HEATING COP @80°F	5.5	4.2	5.5	4.4

FOR MORE INFORMATION, PLEASE CALL 1-844-SANCO₂ OR EMAIL info@eco2systemsllc.com



ECO₂ Systems LLC
P.O. Box 1358, Walled Lake, Mi 48390

Phone: 1-844-726-3262 or 1-844-SANCO₂
E-Mail: info@eco2systemsllc.com
Web: www.eco2waterheater.com

ECO₂ Dealer